

CONCRETE CURB
AND GUTTER
(SEE PLATE STR-1)

EXPANSION
JOINT

5" MINIMUM CONCRETE
6" AGGREGATE BASE, CL.5

EXPANSION
JOINT

SECTION
CONCRETE DRIVEWAY

NOTES:

1. SAW JOINTS 2" DEEP @ 10' MAX SPACING WITHIN 12 HRS OF PLACEMENT. FILL JOINT WITH SEALANT

CONCRETE CURB
AND GUTTER
(SEE PLATE STR-1)

1 1/2" BIT - TYPE SPWEA240B
1 1/2" BIT - TYPE SPWEA240B
6" AGGREGATE BASE, CL.5

SECTION
BITUMINOUS DRIVEWAY

PLACE BITUMINOUS
IN SEPARATE LIFTS

MATCH CONC. DRIVEWAY PAVEMENT
TO BACK OF CONC. CURB & GUTTER

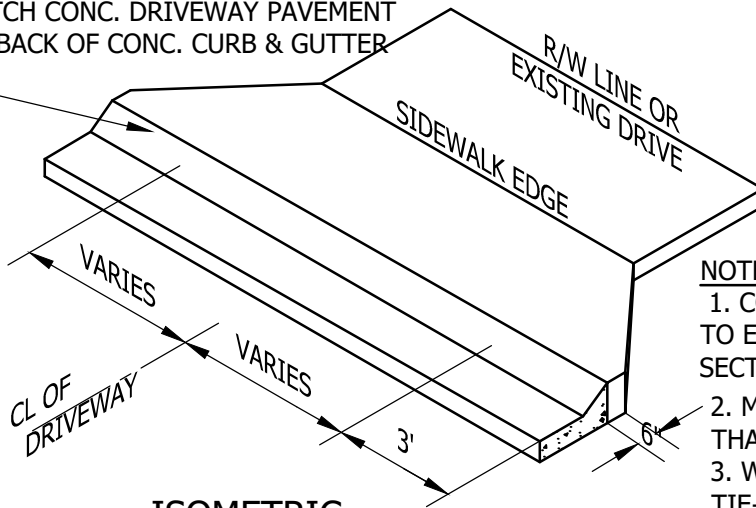

ISOMETRIC

NOTES:

1. CONTROL JOINTS IN CONCRETE CURB NOT TO EXCEED 10' SPACING THROUGH DRIVEWAY SECTION.
2. MATCH EX. DRIVEWAY SECTION IF GREATER THAN SHOWN.
3. WHERE SIDEWALK IS NOT PRESENT 3:1 WING TIE-IN TO BE DETERMINED BY ENGINEER.



**RESIDENTIAL DRIVEWAY
OR ALLEY SECTION
(SURMOUNTABLE CURB)**

LAST REVISION:
DEC 2018

PLATE NO.
STR-3A